

EXHIBIT B

Trials@uspto.gov
571-272-7822

Paper 78
Entered: January 29, 2016

UNITED STATES PATENT AND TRADEMARK OFFICE

BEFORE THE PATENT TRIAL AND APPEAL BOARD

ORACLE CORPORATION and NETAPP INC.,
Petitioner,

v.

CROSSROADS SYSTEMS, INC.,
Patent Owner.

Case IPR2014-01207
Patent 7,051,147 B2

Before NEIL T. POWELL, KRISTINA M. KALAN, J. JOHN LEE, and
KEVIN W. CHERRY, *Administrative Patent Judges*.

KALAN, *Administrative Patent Judge*.

FINAL WRITTEN DECISION
35 U.S.C. § 318(a) and 37 C.F.R. § 42.73

IPR2014-01207
Patent 7,051,147 B2

I. INTRODUCTION

Oracle Corporation and NetApp Inc. (collectively, “Petitioner”)¹ filed a Petition (Paper 1, “Pet.”) to institute an *inter partes* review of claims 14–39 of U.S. Patent No. 7,051,147 B2 (Ex. 1001, “the ’147 patent”) pursuant to 35 U.S.C. §§ 311–319. Crossroads Systems, Inc. (“Patent Owner”) filed a Preliminary Response (Paper 11, “Prelim. Resp.”).

On February 2, 2015, we instituted trial as to claims 14–39 of the ’084 patent. Paper 12 (“Dec.”). During trial, Patent Owner filed a Patent Owner Response (Paper 29, “PO Resp.”), which was accompanied by a Declaration from John Levy, Ph.D. (Ex. 2053). Petitioner filed a Reply to the Patent Owner Response. Paper 45 (“Reply”). An oral hearing was held on October 30, 2015. A transcript of the consolidated hearing has been entered into the record. Paper 77 (“Tr.”).

Petitioner filed a Motion to Exclude (Paper 59) and Reply in support of the Motion to Exclude (Paper 71). Patent Owner filed an opposition to Petitioner’s Motion to Exclude (Paper 64).

Patent Owner also filed a Motion to Exclude (Paper 61) and Reply in support of the Motion to Exclude (Paper 70). Petitioner filed an opposition to Patent Owner’s Motion to Exclude (Paper 66).

We have jurisdiction under 35 U.S.C. § 6. This Final Written Decision is issued pursuant to 35 U.S.C. § 318(a) and 37 C.F.R. § 42.73.

¹ Huawei Technologies Co. Ltd. was a Petitioner in the original Petition. Pet. 1. On October 8, 2015, we granted a joint motion to terminate Petitioner Huawei Technologies Co. Ltd. Paper 69.

IPR2014-01207
Patent 7,051,147 B2

We determine that Petitioner has shown by a preponderance of the evidence that claims 14–39 of the ’147 patent are unpatentable.

II. BACKGROUND

A. *Related Matters*

The parties indicate that the ’147 patent is asserted in co-pending matters captioned *Crossroads Systems, Inc. v. Oracle Corp.*, Case No. 1-13-cv-00895-SS (W.D. Tex.) and *Crossroads Systems, Inc. v. NetApp, Inc.*, Case No. 1-14-cv-00149-SS (W.D. Tex.). Pet. 2–3; Paper 9, 3. The ’147 Patent is also involved in IPR2014-01209 and IPR2014-01544.

B. *The ’147 Patent (Ex. 1001)*

The ’147 patent, titled “Storage Router and Method for Providing Virtual Local Storage,” issued on May 23, 2006. The ’147 patent relates to a storage router and storage network where devices (e.g., workstations) connected to a Fibre Channel (“FC”) transport medium are provided access to storage devices connected to a second FC transport medium. Ex. 1001, Abstract. The storage router interfaces with both FC media, mapping workstations on the first FC transport medium, for example, to the storage devices on the second FC transport medium. *Id.* The storage router of the ’147 patent allows access from the workstations to the storage devices using “native low level, block protocol.” *Id.* One advantage of using such native low level block protocols is greater access speed when compared to network protocols that must first be translated to low level requests, and vice versa, which reduces access speed. *Id.* at 1:58–67.

C. *Illustrative Claim*

Claim 14 of the ’147 patent is reproduced below:

IPR2014-01207

Patent 7,051,147 B2

14. An apparatus for providing virtual local storage on a remote storage device to a device operating according to a Fibre Channel protocol, comprising:

a first controller operable to connect to and interface with a first transport medium, wherein the first transport medium is operable according to the Fibre Channel protocol;

a second controller operable to connect to and interface with a second transport medium, wherein the second transport medium is operable according to the Fibre Channel protocol; and

a supervisor unit coupled to the first controller and the second controller, the supervisor unit operable to control access from the device connected to the first transport medium to the remote storage device connected to the second transport medium using native low level, block protocols according to a map between the device and the remote storage device.

Ex. 1001, 11:5–22.

D. Prior Art Supporting Instituted Unpatentability Grounds

1. CRD-5500 SCSI RAID Controller User's Manual (1996) ("CRD Manual") (Ex. 1003);
2. CRD-5500 SCSI RAID Controller Data Sheet (Dec. 4, 1996) ("CRD-5500 Data Sheet") (Ex. 1004);
3. Judith A. Smith & Meryem Primmer, *Tachyon: A Gigabit Fibre Channel Protocol Chip*, HEWLETT-PACKARD J. 1, 1–17 (1996) ("Smith") (Ex. 1005);
4. U.S. Patent No. 6,219,771 B1, issued Apr. 17, 2001 ("Kikuchi") (Ex. 1006);
5. U.S. Patent No. 6,073,209, issued June 6, 2000 ("Bergsten") (Ex. 1007); and
6. JP Patent Application Pub. No. Hei 5[1993]-181609, published July 23, 1993 ("Hirai") (Ex. 1008).

Petitioner also relies on the Declaration of Professor Jeffrey S.

Chase, Ph.D. (Ex. 1010, "Chase Declaration").

IPR2014-01207
 Patent 7,051,147 B2

E. Instituted Unpatentability Grounds

We instituted an *inter partes* review of claims 14–39 of the '147 patent on the following grounds:

References	Basis	Claims Instituted
CRD Manual, CRD-5500 Data Sheet, and Smith	§ 103	14–39
Kikuchi and Bergsten	§ 103	14–39
Bergsten and Hirai	§ 103	14–39

III. ANALYSIS

For the challenged claims, Petitioner must prove unpatentability by a preponderance of the evidence. 35 U.S.C. § 316(e). We begin with a claim construction analysis, and then follow with specific analysis of the prior art.

A. Claim Interpretation

The Board interprets claim terms in an unexpired patent using the “broadest reasonable construction in light of the specification of the patent in which [they] appear[.]” 37 C.F.R. § 42.100(b); *see* Office Patent Trial Practice Guide, 77 Fed. Reg. 48,756, 48,766 (Aug. 14, 2012). Under the broadest reasonable interpretation standard, claim terms are given their ordinary and customary meaning in view of the specification, as would be understood by one of ordinary skill in the art at the time of the invention. *In re Translogic Tech., Inc.*, 504 F.3d 1249, 1257 (Fed. Cir. 2007). Only those terms which are in controversy need be construed, and only to the extent necessary to resolve the controversy. *Vivid Techs., Inc. v. Am. Sci. & Eng’g, Inc.*, 200 F.3d 795, 803 (Fed. Cir. 1999).

IPR2014-01207
Patent 7,051,147 B2

During trial, the parties disputed the claim construction of the term “map between the device and the remote storage device,” which we address below. No other claim terms require express construction to resolve the issues raised in this *inter partes* review.

Claim 14 recites “a supervisor unit . . . operable to control access . . . according to a *map between the device and the remote storage device.*” (emphasis added). Each challenged independent claim recites a similar limitation. This term was not construed expressly in the Decision on Institution.

Patent Owner argues that the term “requires that the map specifically identify the host (through some representation of that host) and its associated storage (through some representation of that storage) in order to allocate storage to particular hosts.” PO Resp. 3. Further, Patent Owner makes clear its position that the recited mapping requires the storage devices to be mapped directly to a particular device, such as a host computer. *Id.* at 2–3, 36. According to Patent Owner, it is not enough to map between a storage device and an intermediate identifier associated with a particular device because the identifier is not directly and immutably associated with the device itself—in other words, mapping to an identifier is insufficient unless the identifier is associated with a particular device and *cannot* be associated with any other device. *See id.* at 41–47 (arguing that mapping to a channel identifier does not suffice, even if the channel is connected to only one host device, because the channel identifier *could* be associated with another device if another device were connected to that channel).

IPR2014-01207

Patent 7,051,147 B2

The construction proposed by Patent Owner is overly narrow. Although Patent Owner emphasizes that the map must identify specific host devices, it does not explain persuasively why the claim language should be construed to exclude doing so via intermediate identifiers. *See* PO Resp. 2–3. Patent Owner does not identify any disclosure in the ’147 patent’s specification that clearly disavows mapping to a device indirectly, or mapping to a device via an intermediate identifier that could identify a different host if the system were configured differently. *See Gillette Co. v. Energizer Holdings, Inc.*, 405 F.3d 1367, 1374 (Fed. Cir. 2005) (holding that “words or expressions of manifest exclusion or explicit disclaimers in the specification are necessary to disavow claim scope” (internal quotations omitted)). Its discussion of Figure 3, for example, is insufficient to compel a narrow construction of the term because it analyzes only a preferred embodiment of the invention. PO Resp. 45–46; *see, e.g., In re Am. Acad. of Sci. Tech Ctr.*, 367 F.3d 1359, 1369 (Fed. Cir. 2004) (holding that limitations should not be imported from preferred embodiments into the claims absent a clear disclaimer of claim scope in the specification).

Moreover, the ’147 patent specifically discusses mapping with identifiers that are not immutable. For example, the specification discusses addressing devices on an FC loop using an AL_PA (arbitrated loop physical address), and the possibility of “FC devices changing their AL-PA due to device insertion or other loop initialization.” Ex. 1001, 8:40–46; Reply 3–6 (discussing evidence supporting the use of intermediate identifiers, including testimony by Patent Owner’s proffered expert).

IPR2014-01207

Patent 7,051,147 B2

Further, the challenged claims of the '147 patent indicate the mapping may use mere representations of a device rather than requiring direct mapping to the device itself. Claim 15, for example, recites mapping including “virtual LUNs that provide a representation of the storage device,” and claim 17 recites “mapping from a host device ID to a virtual LUN representation of the remote storage device.” Although these claims refer to “virtual” representations of storage devices rather than host devices, the “maps between” term of the independent claims uses the same language when referring to both the devices and storage devices—for example, claim 14 merely recites a “map between the device and the remote storage device.” The claim language does not indicate that the mapping may address storage devices one way, but that devices must be addressed in a different, more specific or direct way.

For the reasons above, we are not persuaded that the broadest reasonable interpretation of “map between the device and the remote storage device” mandates mapping directly or immutably to a host device itself, or excludes mapping to devices using intermediate identifiers.

The parties note that a district court in a related case construed the term as follows, and the Special Master in the co-pending litigation between the parties recommended adoption of this construction:

To create a path from a device on one side of the storage router to a device on the other side of the router. A “map” contains a representation of devices on each side of the storage router, so that when a device on one side of the storage router wants to communicate with a device on the other side of the storage router, the storage router can connect the devices.

Ex. 2034, 4; *see also* PO Resp. 2. Although we are not bound by the construction or reasoning of the district court, we do not disregard the

IPR2014-01207

Patent 7,051,147 B2

analysis and conclusions of a court construing the same claim term in a concurrent proceeding concerning the same patent. *Power Integrations, Inc. v. Lee*, 797 F.3d 1318, 1326–1327 (Fed. Cir. 2015) (discussing the Board’s error in declining to address or acknowledge the district court’s claim construction). After considering the construction of the district court, we determine this construction corresponds to the broadest reasonable interpretation and adopt it for purposes of this Decision.

B. Asserted Ground Based on CRD Manual, CRD-5500 Data Sheet, and Smith

Petitioner challenges claims 14–39 as obvious under 35 U.S.C. § 103 over CRD Manual, CRD-5500 Data Sheet, and Smith. Pet. 12–27. As discussed below, Petitioner has demonstrated by a preponderance of the evidence that all challenged claims are unpatentable on this ground.

1. The CRD Manual

The CRD Manual describes the CRD-5500 RAID controller, a device that enables access to an array of disk drives on a SCSI bus. Ex. 1003, 9.² This controller has a modular design that permits customization of its I/O channels using different I/O hardware modules, which allow support of multiple hosts and multiple drives. *Id.* at 9–11.

2. The CRD-5500 Data Sheet

The CRD-5500 Data Sheet discusses the benefits and features of the CRD-5500 RAID controller. Ex. 1004. Specifically, it provides that “CMD’s advanced ‘Viper’ RAID architecture and ASICs were designed to

² For clarity, we refer to the pagination of Exhibit 1004 provided by Petitioners and not its native pagination.

IPR2014-01207

Patent 7,051,147 B2

support tomorrow's high speed serial interfaces, such as Fiberchannel (FCAL) and Serial Storage Architecture (SSA).” *Id.* at 1.

3. *Smith*

Petitioner relies on an article titled “Tachyon: A Gigabit Fibre Channel Protocol Chip.” Ex. 1005. This article discusses the Tachyon chip, an FC interface controller that “enables a seamless interface to the physical FC-0 layer and low-cost [FC] attachments for hosts, systems, and peripherals on both industry-standard and proprietary buses through the Tachyon system interface.” *Id.* at 1.

4. *Analysis*

Petitioner asserts, in a section of the Petition titled “The Combined System of *CRD-5500 User Manual*, *CRD-5500 Data Sheet* and *Smith*,” that the references, in combination, disclose the claimed subject matter. Pet. 16–19 (including a figure representing the hypothetical combined system on page 18). In the “Correspondence between Claims 14–39 and the Combined System of *CRD-5500* and *Smith*” section, Petitioner alternately refers to the references and to paragraphs in the Chase Declaration in support of its arguments. *Id.* at 19–27. Petitioner presents specific arguments with respect to claims 14–20, and then, for claims 21–39, relies on its arguments for claims 14–20 and the Chase Declaration. *Id.* at 24–27.

Petitioner argues that the disclosures of the CRD Manual and CRD-5500 Data Sheet disclose substantially all the limitations of claims 14–20, apart from the “first controller” and “second controller,” which Petitioner argues are disclosed by the incorporation of Smith’s Tachyon chip into an FC host interface module and into a FC storage interface module,

IPR2014-01207

Patent 7,051,147 B2

respectively. *Id.* at 19–22. Petitioner further argues that it would have been obvious to one of ordinary skill in the art to combine the CRD-5500 references and Smith “to enhance the communication and storage options of a host device on a FC transport medium, benefit from the ‘Host LUN Mapping’ feature of the CRD-5500 controller, and avail the host computing device of ubiquitous mass storage applications (*e.g.*, RAID).” *Id.* at 16 (citing Ex. 1010 ¶¶ 39–43). We adopt Petitioner’s reasoning for combining the references as supported by the record, including Dr. Chase’s Declaration. Patent Owner includes a section in its Patent Owner Response titled “Petitioner’s Reasons for Combining Do Not Lead to the Claimed Invention,” but this short section focuses primarily on Patent Owner’s allegation that the recited combination would still lack the features of the claimed invention. PO Resp. 53–54. Thus, Patent Owner has not persuasively presented arguments to counter Petitioner’s position that a person of ordinary skill would have had reason to combine the teachings of these references.

The Petition identifies the “first controller” and the “second controller” as being created “through the incorporation of the Tachyon chip” into a FC host interface module and into a FC storage interface module, respectively. Pet. 20. The Petition identifies the CPU disclosed in the CRD Manual as teaching the recited “supervisor unit.” *Id.* at 21. The CRD Manual describes a feature of its Monitor Utility used to “map LUNs on each host channel to a particular redundancy group.” Ex. 1003, 44. Petitioner argues that the CRD-5500 controls access by using this “Host LUN Mapping,” which accepts only host LUN addresses for which a redundancy group mapping associated with the requesting host exists.

IPR2014-01207

Patent 7,051,147 B2

Pet. 21. The map limitation, according to Petitioner, is evidenced by the “Host LUN Mapping” used to map between LUNs assigned to the host device and RAID redundancy groups each representing a physical storage drive. *Id.* The hosts in the proposed combination communicate the LUN to the CRD-5500 in SCSI commands; the ’147 patent discloses that SCSI is an example of a “native low level, block protocol” within the meaning of the claims. *Id.*; Ex. 1001, 5:13–17, 5:46–50. Based on the full record after trial, we find that the combination of the CRD Manual and the HP Journal teaches or suggests each limitation of the challenged claims of the ’147 patent. Patent Owner’s counterarguments are unpersuasive.

Patent Owner argues the asserted combination does not teach the “Fibre Channel transport medium,” “mapping,” and “access controls/controlling access” functions of the patent. PO Resp. 36–51.

First, Patent Owner challenges Petitioner’s assertion that the Tachyon chip passes the host device identity to the CRD-5500 controller processor, where the host device information is cross-referenced with the “Host LUN Mapping” maintained by the CRD-5500 controller to identify storage. *Id.* at 38. Patent Owner faults Dr. Chase for failing to cite to evidence supporting that the CRD-5500 matches the combination of LUN and host identification in the SCSI command with a RAID redundancy group, providing testimony from Dr. Levy that the CRD-5500 would not operate in this manner. *Id.* at 39 (citing Ex. 1010 ¶ 42; Ex. 2053 ¶¶ 200–201). Petitioner relies on its arguments in the Petition and on Dr. Chase’s testimony to respond that, in certain implementations, host device identity is passed directly to the CRD controller. Reply 6–7 (citing Pet. 18–19; Ex. 1010 ¶ 42 (discussing identification of the host by the “FC unique

IPR2014-01207
 Patent 7,051,147 B2

identifier’’), 8–9 (discussing this limitation in relation to claims 17, 24, and 36). Patent Owner does not explain persuasively why this disclosure or implementation should be overlooked. Based on Petitioner’s evidence regarding the passing of host device identity to the CRD controller, including Dr. Chase’s credible testimony, we are persuaded that the sending host would be identifiable in this implementation.

Patent Owner next alleges that the CRD Manual fails to teach the recited mapping because the host LUN mapping feature only maps storage devices to host *channels*, not the specific hosts themselves. PO Resp. 41–47 (citing Ex. 2053 ¶¶ 203, 205, 212–13, 218–19, 221, 223, 229–31, 233), 50 (discussing the limitation in relation to claims 15 and 22). This argument, however, relies on the overly narrow claim construction rejected above, and is unpersuasive as a result. For example, Patent Owner addresses Figure 1-2 of the CRD Manual, which is reproduced below:

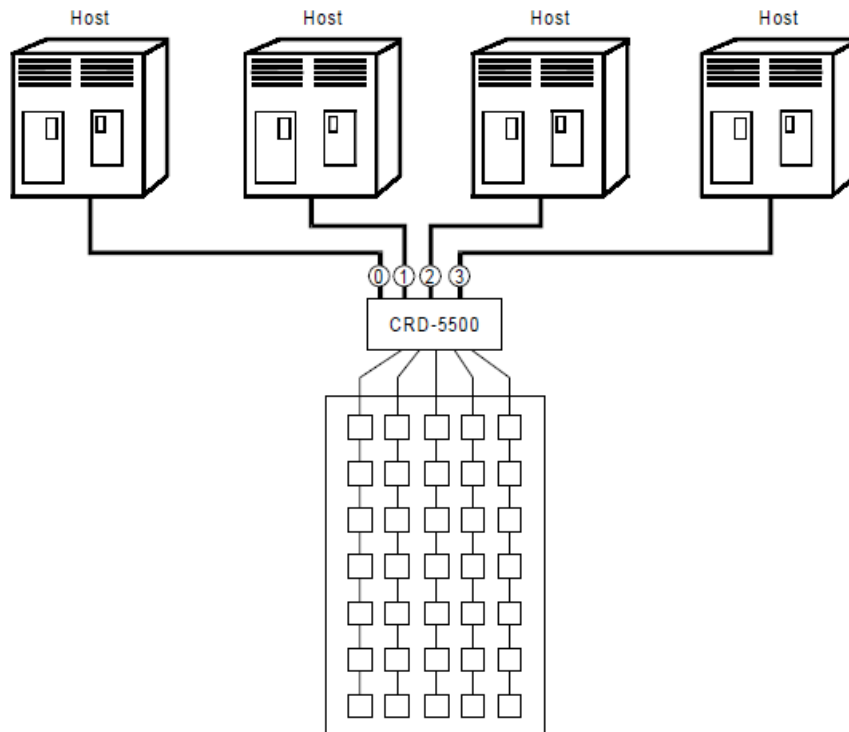

IPR2014-01207

Patent 7,051,147 B2

Figure 1-2 of the CRD Manual depicts a configuration of the CRD-5500 controller where each of four different hosts are assigned to a different channel, i.e., channel 0 through channel 3. Ex. 1003, 10. These hosts may then access redundancy groups via the CRD-5500 controller. *Id.*

The specific configuration depicted in Figure 1-2 meets the mapping limitation because each host channel is dedicated to a single host—thus, in effect, mapping to a host channel is tantamount to mapping to a particular host. *See* Reply 3–5. In recognition of this fact, the CRD Manual explicitly refers to mapping to hosts and host channels interchangeably, which Patent Owner acknowledges at least with respect to Figure 1-2. *See* Ex. 1003, 9; PO Resp. 44; Reply 4–5. The analysis presented by Patent Owner regarding other configurations *different* from that in Figure 1-2—i.e., configurations where two hosts are connected to the same host channel (PO Resp. 45)—does not cancel or negate the configuration disclosed by Figure 1-2. As discussed above, the broadest reasonable interpretation of the mapping limitation is not limited only to mapping directly and immutably to a specific host device, and does not exclude categorically the use of intermediate identifiers. Consequently, Patent Owner has not shown persuasively why the configuration disclosed in the CRD Manual falls outside the scope of the claim language.

Patent Owner additionally contends that the CRD Manual fails to teach the access controls limitations of the challenged claims. *Id.* at 47–50. Similar to its arguments relating to the mapping limitation, Patent Owner purports to show how the redundancy group access controls of the CRD Manual can be defeated by changing the disclosed configuration in Figure 1-2, i.e., by rewiring the hosts such that multiple hosts are connected to the

IPR2014-01207

Patent 7,051,147 B2

same host channel. *Id.* at 48–49. Patent Owner has not persuasively demonstrated, however, that the purported inadequacy of the access control method disclosed for the Figure 1-2 configuration, when directly applied to a *different* configuration, shows that the CRD Manual fails to teach implementing access controls at least for the configuration of Figure 1-2.

Lastly, Patent Owner argues that no evidence exists that the CRD-5500 could accommodate Smith’s Tachyon chip FC host interface. PO Resp. 51–53. Patent Owner critiques the statement in Exhibit 1004 stating that the architecture of the technology supports FC as “forward-looking and speculative.” *Id.* at 51. Petitioner counters that a proper obviousness analysis does not require bodily incorporation. Reply 7–8; *see also In re Keller*, 642 F.2d 413, 425 (CCPA 1981) (“The test for obviousness is not whether the features of a secondary reference may be bodily incorporated into the structure of the primary reference; nor is it that the claimed invention must be expressly suggested in any one or all of the references. Rather, the test is what the combined teachings of the references would have suggested to those of ordinary skill in the art.”). Moreover, Petitioner states that neither Patent Owner nor Dr. Levy asserts that the proposed combination would have been outside the level of ordinary skill in the art to adapt. *Id.* at 8 (citing Ex. 2053 ¶¶ 192–223; Ex. 1010 ¶¶ 39–40). Regarding this issue, the record as a whole supports Petitioner’s contention that a person of ordinary skill would have been able to combine the teachings of the CRD Manual, CRD-5500 Data Sheet, and Smith to arrive at a system in which the CRD-5500 could accommodate the Tachyon chip FC host interface. Ex. 1010 ¶¶ 39–41.

IPR2014-01207

Patent 7,051,147 B2

Claims 15–20 depend, directly or indirectly, from claim 14 and recite limitations similar to those recited in claim 1 and its dependent claims. Both parties rely on essentially the same arguments as those discussed above for the previous claims. *See* Pet. 22–24; PO Resp. 36, 50–51. For reasons similar to those discussed above for the previous claims, we find the full record after trial supports Petitioners’ contention that the asserted prior art teaches each limitation of claims 15–20.

Each of the remaining independent claims (claims 21, 28, and 34), as well as their dependent claims (claims 22–27, 29–33, and 35–39) recite limitations similar to those recited in previous claims discussed above. The parties advance similar arguments and evidence with respect to these claims as for those previous claims. *See* Pet. 24–27; PO Resp. 36, 50–51. For similar reasons as discussed above, we find the full record after trial supports Petitioners’ contention that the asserted prior art teaches each limitation of claims 21–39.

In sum, based on the full record after trial, we find that a preponderance of the evidence supports Petitioner’s contention that the combination of CRD Manual, CRD-5500 Data Sheet, and Smith teaches or suggests each limitation of claims 14–39. As discussed below, we are not persuaded that Patent Owner has established secondary considerations of non-obviousness. Thus, Petitioner has shown by a preponderance of the evidence that claims 14–39 are unpatentable under 35 U.S.C. § 103(a).

C. Asserted Ground Based on Kikuchi and Bergsten

Petitioner challenges claims 14–39 as obvious under 35 U.S.C. § 103 over Kikuchi and Bergsten. Pet. 27–42.

IPR2014-01207

Patent 7,051,147 B2

1. Kikuchi

Kikuchi is titled “Data Storage Apparatus with Improved Security Process and Partition Allocation Functions,” and discloses an apparatus that enables access authorization to be assigned solely to specific host devices. Ex. 1006, Abstract. In one embodiment, Kikuchi discloses address offset information conversion unit 121 and actual partition address conversion unit 122, as shown in Figure 5:

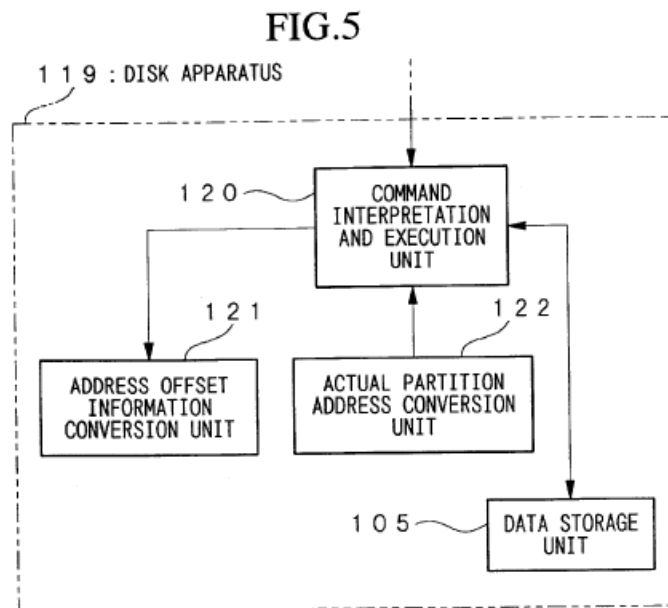

Figure 5 is a diagram showing the configuration of an embodiment of the claimed invention of Kikuchi, in which offset information indicating a disk partition corresponding to each host device has been stored in advance in the address offset information conversion unit 121, and the host address input from command interpretation and execution unit 120 is converted to this offset information. *Id.* at 3:48–49, 7:55–63. In this embodiment, actual partition address conversion unit 122 combines the disk partition address output from command interpretation and execution unit 120 with

IPR2014-01207

Patent 7,051,147 B2

the offset information output from address offset information conversion unit 121 to generate an actual disk partition address. *Id.* at 7:64–8:3.

2. *Bergsten*

Bergsten is titled “Data Storage Controller Providing Multiple Hosts with Access to Multiple Storage Subsystems,” and describes a storage controller that allows multiple host computer systems at different locations to access any of multiple copies of stored data. Ex. 1007, 3:1–4. The storage controller emulates a local storage array for the host computer system that it services, and emulates a host computer system for the local storage array that it accesses. *Id.* at 3:14–17. The host computer systems access stored data using virtual device addresses, which are mapped to real device addresses by the storage controller. *Id.* at 3:17–19. Figure 1 of Bergsten is reproduced below.

IPR2014-01207
 Patent 7,051,147 B2

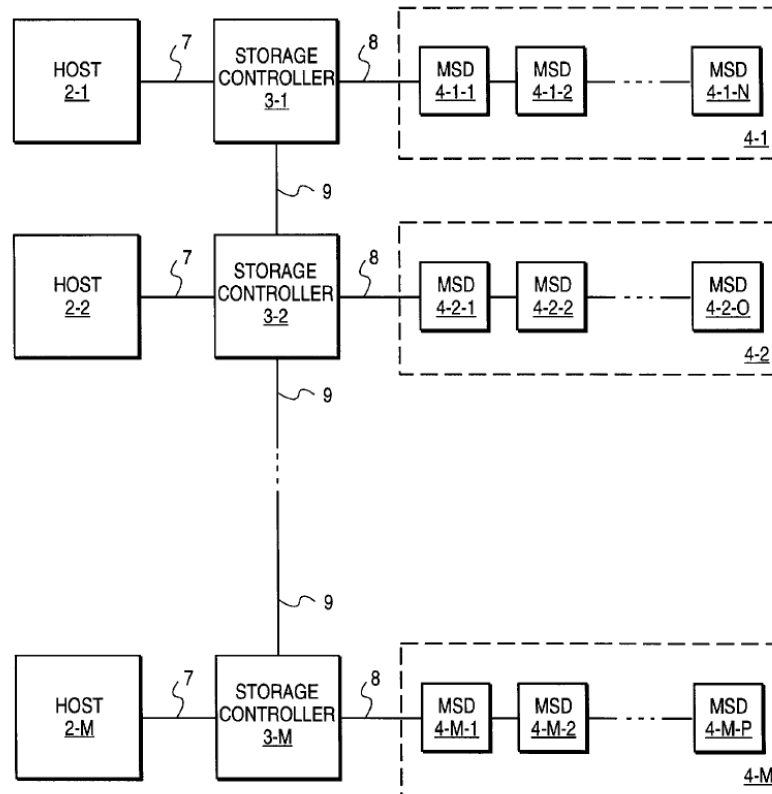

FIG. 1

Figure 1 of Bergsten is a block diagram illustrating a computing system in which a number of Bergsten's storage controllers provide a number of host computer systems with access to a number of storage arrays. *Id.* at 3:20–23. Figure 1 shows a computing system with M storage controllers, 3-1 through 3-M; M host computers, 2-1 through 2-M, which are coupled to storage controllers 3-1 through 3-M, respectively; and M storage arrays 4-1 through 4-M, which are coupled to storage controllers 3-1 through 3-M respectively. *Id.* at 3:23–28. Each of the storage arrays includes a number of mass storage devices (“MSDs”). *Id.* at 3:28–34. Storage controllers 3-1 through 3-M function cooperatively to provide any of host computer systems 2-1 through 2-M with access to any of storage

IPR2014-01207

Patent 7,051,147 B2

arrays 4-2 through 4-M. *Id.* at 4:7–9. Storage controller 3-1 is coupled directly to host computer system 2-1 using data communication path 7 and to local data storage array 4-1 via another communication path 8. *Id.* at 4:13–17. Data communication paths 7 and 8 may conform to a variety of protocols, including SCSI, serial SCSI, Fiber Channel, or ESCON. *Id.* at 4:19–28.

A local host computer accesses data by transmitting a (virtual) host address to its local storage controller. *Id.* at 6:10–11. The host address is then mapped to a real address representing a location on one or more physical MSDs. *Id.* at 6:11–14. The mapping is completely transparent to all of the host computers. *Id.* at 6:14–16. A single host address may map to multiple physical addresses, which may be distributed among multiple MSDs, and such MSDs may further be located in different storage arrays. *Id.* at 6:16–21. The storage controller maintains and uses a tree structure to map the host interface ID and block number to a logical device. *Id.* at 9:21–24, Fig. 8.

3. *Kikuchi as Prior Art*

Patent Owner argues that Kikuchi, which was filed on August 18, 1997, is not prior art. PO Resp. 20. Patent Owner argues that the invention of the '147 patent was conceived as early as March 22, 1997, and that the '147 patent claims priority to U.S. Patent No. 5,941,972, which was filed on December 31, 1997.³ *Id.* More particularly, Patent Owner

³ The '147 patent sets forth its parentage as follows: “Continuation of application No. 10/081,110, filed on Feb. 22, 2002, now Pat. No. 6,789,152, which is a continuation of application No. 09/354,682, filed on Jul. 15, 1999, now Pat. No. 6,421,753, which is a continuation of application No.

IPR2014-01207
Patent 7,051,147 B2

alleges that the invention of the '972 patent, representing the earliest filing in the '147 patent's chain of title, was conceived as early as March 1997. *Id.* at 21. According to Patent Owner: "Only two dates are important for the prior invention analysis. Crossroads must have a complete conception just before Kikuchi's filing date (Aug. 17, 1997) and diligence in reduction to practice (here, constructive reduction to practice on Dec. 31, 1997) ('the critical period')." *Id.* at 23.

During the period in which reasonable diligence must be shown, there must be continuous exercise of reasonable diligence. *In re McIntosh*, 230 F.2d 615, 619 (CCPA 1956); *see also Burns v. Curtis*, 172 F.2d 588, 591 (CCPA 1949) (referring to "reasonably continuous activity"). A party alleging diligence must account for the entire critical period. *Griffith v. Kanamuru*, 816 F.2d 624, 626 (Fed. Cir. 1987); *Gould v. Schawlow*, 363 F.2d 908, 919 (CCPA 1966).

Even a short period of unexplained inactivity is sufficient to defeat a claim of diligence. *Morway v. Bondi*, 203 F.2d 742, 749 (CCPA 1953); *Ireland v. Smith*, 97 F.2d 95, 99–100 (CCPA 1938). In *In re Mulder*, 716 F.2d 1542, 1542–46 (Fed. Cir. 1983), the Federal Circuit affirmed a determination of lack of reasonable diligence, where the evidence of record was lacking for a two-day critical period. Likewise, in *Rieser v. Williams*, 255 F.2d 419, 424 (CCPA 1958), there was insufficient diligence where no activity was shown during the first 13 days of the critical period.

To support its conception date, Patent Owner relies, *inter alia*, on an abstract and drawing sent from the inventor to outside counsel on May 28,

09/001,799, filed on Dec. 31, 1997, now Pat. No. 5,941,972." Ex. 1001, at [63].

IPR2014-01207

Patent 7,051,147 B2

1997, and a draft patent application returned by outside counsel on July 11, 1997, as evidence. PO Resp. 21 (citing Exs. 2300–2303). To support its allegations of reduction to practice, Patent Owner argues that the “precursor to the invention claimed in the ’972 patent was the ‘Verrazano’ project.” *Id.* at 22. According to Patent Owner, “Verrazano was a bridge for linking FC and SCSI devices and contained all elements of the ’972 invention except for access controls and virtual local storage.” *Id.* During the critical period, according to Patent Owner, all of its employees were working to create a viable Verrazano product. *Id.* at 23. “Verrazano would eventually become Crossroads’ CP4100 product,” according to Patent Owner, and because “Verrazano was the basic hardware platform that would be used to support access controls, its development was required before that feature could be added and the entire invention could actually be reduced to practice.” *Id.* at 23–24 (citing *Thompson v. Dunn*, 166 F.2d 443, 447 (CCPA 1948); *Keizer v. Bradley*, 270 F.2d 396, 398–99 (CCPA 1959)). Patent Owner also points to “revising multiple draft patent applications prior to constructive reduction to practice on December 31, 1997” as evidence of diligence. *Id.* at 25.

Petitioner’s arguments address two time periods: the “first time period” from August 18, 1997, to November 25, 1997, during which inventors were engaged in constructive reduction to practice of the Verrazano bridge product, and the “second time period” from November 25, 1997, to December 31, 1997, during which Petitioner was allegedly revising the patent application. Reply 10–15. Petitioner does not provide arguments specifically directed to Patent Owner’s allegations regarding conception.

IPR2014-01207

Patent 7,051,147 B2

Regarding the “first time period,” Petitioner argues that Patent Owner’s attempt to antedate Kikuchi fails because “about four months of the diligence period was dedicated *only* to developing a product that, Patent Owner also admits, was outside the scope of the claims.” *Id.* at 9. During this “first time period” in which inventors were working on the Verrazano bridge product, Petitioner argues that Patent Owner “made a conscious decision to prioritize development of the Verrazano bridge and delay development of the claimed subject matter.” *Id.* at 11. Petitioner disagrees with Patent Owner’s contention that the completion of the Verrazano product was necessary for commencement of work on the access controls. *Id.* at 11–12. Instead, Petitioner argues, “Patent Owner opted to omit the access controls from the Verrazano product to accelerate commercial introduction of that product.” *Id.* at 12.

Regarding the “second time period” from November 25, 1997, to December 31, 1997, Petitioner argues that, although a draft of the patent application from counsel was received by Patent Owner in July 1997, subsequent edits were “so minimal that they could not have accounted for the five week delay.” *Id.* at 14 (citing Ex. 1228). Petitioner summarizes: “A single patent application review meeting and the transmission of a draft patent application with minimal revisions cannot have required more than a couple days of effort. Patent Owner offers no other evidence of diligence during the five week period.” *Id.* at 14–15.

We do not agree with Patent Owner’s assertions that developing the Verrazano product was a necessary precursor to developing access controls. Petitioner’s evidence, including deposition testimony of diligence declarant John Middleton, indicates that Patent Owner could

IPR2014-01207

Patent 7,051,147 B2

have tested access controls during the “first time period,” but decided not to. Reply 11–12 (citing Ex. 1220, 54, 58–59, 63–65). Patent Owner relies on Mr. Middleton’s declaration statement that “until the Verrazano bridge could be completed, Crossroads had no working device which could implement access controls.” Ex. 2305, 3. However, during his deposition, Mr. Middleton stated that Crossroads was interested in “becoming profitable as soon as possible” and agreed that the exclusion of access controls from the Verrazano bridge possibly had to do with reasons relating to interest in early revenue generation and delay of the commercial launch. Ex. 1220, 71:4–5, 71:10–72:22. Mr. Middleton also stated that, during testing, the functionality of the Verrazano hardware prototypes could have included access control functionality. *Id.* at 63:21–64:4. Petitioner’s evidence, in total, indicates Patent Owner made a business decision to develop and launch the Verrazano product, without access controls, because development of access controls would have lengthened the time to market for the Verrazano product. Reply 12–13 (citing Ex. 1220, 70:16–72:22). Thus, Patent Owner cannot rely on *Thompson v. Dunn* to excuse its inactivity in developing access controls. As discussed above, even a short period of unexplained inactivity is sufficient to defeat a claim of diligence, and Patent Owner’s four-month gap of activity exceeds the short periods found to prevent an earlier priority date by the courts. *Morway*, 203 F.2d at 749. Patent Owner’s additional evidence of reasonable diligence during the “second time period” also is insufficient. The minor changes to the patent application during this time period do not represent reasonably continuous activity. Because Patent Owner had a draft application since July 1997, it is unclear if those changes were even

IPR2014-01207

Patent 7,051,147 B2

made during this “second time period,” or if they were made at some other point between drafting and filing the application. Thus, based on the totality of the evidence before us, we are persuaded that Kikuchi is prior art.

4. Arguments

Petitioner asserts, in a section titled “The Combined System of *Kikuchi* and *Bergsten*,” that the references, in combination, disclose the claimed subject matter. Pet. 30–33. Petitioner argues that “[i]n the combined system of *Kikuchi* and *Bergsten*, multi-protocol intercommunication capabilities of the command and interpretation unit described in *Kikuchi* are enhanced by incorporating *Bergsten*’s emulation drivers 21 and physical drivers 22, which are detailed in *Bergsten* with a greater degree of specificity.” *Id.* at 30–31. Petitioner emphasizes that “[t]o the extent that *Kikuchi* fails to explicitly detail every nuance of FCP-based encapsulation and de-encapsulation, the details of *Bergsten*’s emulation drivers 21 and physical drivers 22 more than sufficiently provide specific details.” *Id.* at 31. Based on the full record after trial, we find that the combination of *Kikuchi* and *Bergsten* teaches all of the limitations of the instituted claims. *Id.* at 27–42 (explaining how each limitation is taught by the asserted prior art).

Patent Owner argues that *Bergsten* does not teach the claimed access controls, and *Kikuchi* does not teach the claimed map or access controls. PO Resp. 25. Instead, Patent Owner argues, *Kikuchi*’s simple address offset is designed to create different “partitions of a physical storage device,” and thus does not provide the claimed map or access controls. *Id.* at 26–28. Patent Owner relies on the testimony of Dr. Levy to support its

IPR2014-01207

Patent 7,051,147 B2

assertions that the “simple offset is designed to create different ‘partitions’ of a physical storage device.” *Id.* at 27 (citing Ex. 2053 ¶¶ 149–151).

Patent Owner also argues that access controls are not present in the asserted combination, because Bergsten’s emulation driver prevents host identity from reaching any map. *Id.* at 32–34.

Petitioner replies that the combination of Kikuchi and Bergsten does in fact restrict access to specific host devices, in that the “correlation chart and address conversion units described in *Kikuchi* are modified to include the virtual mapping functionality of *Bergsten*’s storage controller.”

Reply 16. Regarding Dr. Levy’s testimony that Kikuchi does not really talk about disk partitions, Petitioner argues that Dr. Levy fails to understand properly the operation of Kikuchi, and furthermore attacks Kikuchi individually. *Id.* at 15–16 (citing *Keller*, 642 F.2d at 426).

Petitioner supports its argument by citing to portions of Kikuchi stating that Kikuchi’s apparatus “enables access authorization to be assigned solely to specific host devices.” *Id.* at 17 (citing Ex. 1006, Abstract, 1:65–2:6, 8:40–46). Petitioner also states that Kikuchi, as a form of access control, evaluates the host address to determine whether a host has any rights to access the storage device. *Pet.* 28 (citing Ex. 1006, 4:35–44); *Tr.* 20:22–25. According to Petitioner, there is no express support for Patent Owner’s contention that the Kikuchi host ID would be stripped from the combination. *Tr.* 23:11–15. Petitioner argues that, based on the asserted combination set forth in the Petition, Kikuchi has the ability to extract the host device ID and communicate it on, even in an FC embodiment such as that in Bergsten. *Pet.* 28; *Tr.* 23:17–24:2. As disclosed in Bergsten and discussed by Dr. Chase, Bergsten’s host ID identifies the particular host,

IPR2014-01207
Patent 7,051,147 B2

and is received by the storage controller in Bergsten. Ex. 1007, 9:8–20, Fig. 7; Tr. 63:9–17; Ex. 1010 ¶¶ 299, 313.

We agree with Petitioner that Kikuchi’s disclosure of access authorization assigned to specific host devices meets the “access control” limitation of the claims. In the sections of Kikuchi cited by Petitioner, Kikuchi expressly states that host addresses that match those in an address registration are given access authorization, and certain hosts receive access to certain portions of the disk based on their access authorization, which demonstrates the presence of “access control.” Ex. 1006, Abstract, 1:65–2:6, 4:35–44, 8:37–46. We agree that the express disclosures of Kikuchi should be given substantial weight in our consideration of whether Kikuchi discloses access controls. Additionally, based on the evidence presented, including the disclosures of Bergsten itself and the testimony of Dr. Chase, we are not persuaded that Bergsten prevents host identity from reaching any map. Petitioner’s citations to Bergsten and to Kikuchi support the position that the host ID in each system, or the combined system, is used for mapping purposes rather than being stripped or discarded.

Patent Owner also argues that the asserted combination impermissibly enhances both Kikuchi and Bergsten by ignoring their purposes and modifying their principles of operation. PO Resp. 28. Specifically, Patent Owner argues that one of ordinary skill in the art would not modify the references as proposed by Petitioner, as the combination is highly complex and destroys the intended purposes of both references by modifying their principles of operation. *Id.* at 28–32.

Petitioner responds by arguing that the proposed combination does not change the principles of operation, stating that both parties’ experts

IPR2014-01207

Patent 7,051,147 B2

agree that “making modifications of the type described by Patent Owner would have been rudimentary and well within the skill of an ordinary artisan in this field,” such as changing between a mapping tree (as in Bergsten) and a mapping chart (as in Kikuchi). Reply 17 (citing Ex. 1218, 103; Ex. 1010 ¶ 145, Ex. 2054, 200, 214).

We credit the testimony of Dr. Chase that one of ordinary skill in the art would have been motivated and able to combine Kikuchi and Bergsten in the manner proposed by Petitioner. Ex. 1010 ¶¶ 142–147; Ex. 2054, 180–213. Patent Owner’s arguments to the contrary address the purported complexity of the combination, but do not establish that a person of ordinary skill would not have had a reasonable expectation of success. Obviousness does not require absolute predictability. *In re Kronig*, 539 F.2d 1300, 1304 (CCPA 1976). Both experts agree that the modifications were within the level of ordinary skill in this field (Ex. 1010 ¶ 145; Ex. 1218, 103:16–21). Dr. Chase’s Declaration states that tables and trees are interchangeable data lookup constructs for address translations, and that the “tree mapping” of Bergsten may be collapsed into a simple mapping table construct such as that of Kikuchi in a single-controller implementation; his deposition testimony provides greater detail in response to Patent Owner’s questions on how the collapsing would occur in different circumstances. Ex. 1010 ¶ 145; 2054, 180–219. Thus, we are persuaded by Petitioner’s testimony and evidence that the combination of Kikuchi and Bergsten was within the skill level of an ordinarily skilled artisan, and would not change the principles of operation of the respective references.

IPR2014-01207
Patent 7,051,147 B2

Finally, Patent Owner argues that Petitioner has not provided a motivation to combine Kikuchi and Bergsten. PO Resp. 35–36. According to Petitioner, one of ordinary skill in the art would have been motivated to combine Kikuchi and Bergsten to “improve the *Kikuchi* system with the advantage of virtualized, networked storage,” to “increase both the number of storage devices accessible to hosts and the storage address range available,” and to “benefit from increased restructuring capabilities.” Pet. 32–33 (citing Ex. 1010 ¶ 142–147); Reply 13 (citing Ex. 1010 ¶ 146). Patent Owner challenges each of these statements, and the supporting testimony, as lacking evidence supporting how Bergsten would provide the alleged benefits or explaining why one of ordinary skill in the art would be motivated to combine the references as proposed by Petitioner. PO Resp. 35–36.

Here, too, we credit the testimony of Dr. Chase that one of ordinary skill in the art would have been motivated to combine Kikuchi and Bergsten in the manner proposed by Petitioner. Ex. 1010 ¶¶ 142–147. Bergsten itself indicates that it would be “desirable” for a storage controller to not be “dependent on any particular hardware or software configuration of any host computer or mass storage device which it services.” Ex. 1007, 1:48–51. The numerous reasons articulated by Petitioner for the combination of Kikuchi with Bergsten, resulting in an enhanced system with advantages including virtualized storage, increased capacity and increased flexibility, are detailed by Petitioner and supported by testimony. *KSR Int’l Co. v. Teleflex Inc.*, 550 U.S. 398, 421–22 (2007). Patent Owner’s arguments to the contrary are unavailing.

IPR2014-01207

Patent 7,051,147 B2

As discussed below, we are not persuaded that Patent Owner has established secondary considerations of non-obviousness. Accordingly, we find that Petitioner has demonstrated by a preponderance of the evidence that claims 14–39 are obvious over Kikuchi and Bergsten.

D. Asserted Grounds Based on Bergsten and Hirai

Petitioner challenges claims 14–39 as unpatentable over Bergsten and Hirai. Pet. 42–55.

1. Hirai

Hirai is a Japanese published patent application titled “Personal Computer System.” Ex. 1008, (54). Hirai describes a personal computer system that allows the sharing of multiple magnetic disk devices by multiple personal computers. *Id.* at Abstract. The multiple disks are considered as one virtual magnetic disk device with a partition control table that manages and specifies the access right of the personal computers connected to the sharing device for each partition of the memory region of the virtual magnetic disk device. *Id.* ¶¶ 5, 11, 12. The access right to a partition includes R (read), W (write), C (create), D (delete), and X (execute). *Id.* ¶ 12. Figure 2 of Hirai is reproduced below.

IPR2014-01207
 Patent 7,051,147 B2

Partition	Computer name	Access right
Partition 1	Personal computer 1	RWCX
	Personal computer 2	RWCX
	Personal computer 3	RWCX
Partition 2	Personal computer 1	RW
	Personal computer 3	R
Partition 3	Personal computer 1	R
	Personal computer 2	R
Partition n	.	.
	.	.
	.	.
	.	.

(R: Readable, W: Writable, C: Creatable, X: Executable)

Figure 2

Figure 2 shows an example of a partition control table. For example, Personal computer 1 can read, write create, and execute with a partition 1, read and write with a partition 2, and read with a partition 3. *Id.* ¶ 13. The system can prevent illegal access from a personal computer that is not authorized. *Id.*

2. Analysis

Petitioner asserts, in a section titled “The Combined System of *Bergsten* and *Hirai*,” that the references, in combination, disclose the claimed subject matter. Pet. 44–47. Petitioner argues that “[i]n the combined system [of *Bergsten* and *Hirai*], *Hirai*’s access controls are incorporated into *Bergsten*’s storage controllers.” Pet. 45. Petitioner contends that “[t]o the extent that Patent Owner attempts to argue that *Bergsten* may lack explicit and nuanced detail regarding the implementation of access controls and the ramifications of write-protecting data . . . the access control map described in *Hirai* is detailed with a greater

IPR2014-01207

Patent 7,051,147 B2

degree of particularity.” *Id.* Petitioner explains that in the combined system, the storage controller “maps the identification of the host device and the host address within the command to a logical storage location and verifies that the access type (which is requested within the storage command) matches the access controls specified for the host device for the particular logical storage location.” *Id.* at 45–46 (citing Ex. 1010 ¶¶ 248–250). Petitioner reasons that “[a]n artisan skilled in network storage during the relevant timeframe would combine the *Bergsten* and *Hirai* teachings in the above-described manner in order to provide additional levels of granularity to the access controls of the *Bergsten* system based on the mapping-based access controls of *Hirai*.” *Id.* at 46.

Patent Owner disputes whether *Bergsten* or *Hirai*, either alone or in combination, teach or suggest certain limitations of claim 14, including that the supervisor unit be operable to allow hosts access to storage using native low level, block protocols. PO Resp. 5–18. Patent Owner raises additional arguments regarding the sufficiency of Petitioner’s obviousness analysis based on reasonable expectation of success and Petitioner’s asserted motivation to combine. *See id.* at 18–19.

We note that the claims require use of native low-level block protocol to effect communication between the controllers. Ex. 1001, 9:23–14:16. The specification emphasizes the importance of native low-level block protocols (“NLLBP”): “storage access involves native low level, block protocols and does not involve the overhead of high level protocols and file systems required by network servers.” *Id.* at 5:14–16. In particular, Patent Owner submits, and Dr. Levy testifies, that *Hirai* does not “allow access . . . using NLLBP” because *Hirai* uses only high level

IPR2014-01207

Patent 7,051,147 B2

file system access rights. PO Resp. 6–7 (citing Ex. 2053 ¶¶ 59, 66, 103–114). Patent Owner contends that Petitioner must impermissibly pick and choose from Hirai’s teachings regarding access rights, ignoring the teaching of Hirai as a whole, to combine it with Bergsten. *Id.* at 10. Patent Owner argues that the combination of Hirai’s file system access controls with the open access system of Bergsten results in “allowing access . . .” in the same manner as the prior art “network servers,” which was the problem identified by the inventors of the ’147 patent. *Id.* at 12.

We are persuaded by Patent Owner’s arguments that Petitioner and its Declarant, Dr. Chase, fail to account for the prior art as a whole and improperly pick and choose from the references in their reasoning to support their contention that the proposed combination of Bergsten and Hirai renders the claims obvious. To begin with, the Petition appears to implicitly assume, without any explanation, that Hirai’s access controls are NLLBP controls, but never provides any explanation for this assumption. Pet. 42–47. Even in its Reply, Petitioner does not attempt to show that Hirai is directed to NLLBP access controls, but instead only argues that Hirai does not disclose high level controls. Reply 19. The only evidence Petitioner provides to support its contentions is the testimony of Dr. Chase. We are not persuaded by Petitioner’s contention and Dr. Chase’s testimony that Hirai is directed to block-level access controls. *See id.*; Ex. 1010 ¶¶ 245–246.

As Patent Owner explains, looking at all of the access rights described in Hirai, the evidence suggests that these are high-level access controls rather than low level block permissions. Ex. 2053 ¶¶ 88–99. We find that the evidence supports Patent Owner’s contentions that all of the

IPR2014-01207

Patent 7,051,147 B2

permissions described in Hirai are consistent with file system permissions, not block level permissions. *See id.* ¶¶ 89–91; Ex. 2048, 28–29 (describing permissions used in Network File System); Ex. 2057, 15 (discussing UNIX file permissions); Ex. 2055, 308:25–310:7 (explaining that read, write, create, and execute are standard file system permissions). We also agree with Patent Owner that, based on the record currently before us, a person of ordinary skill would not understand Hirai to disclose block level access controls. Ex. 2053 ¶ 92. Such a reading is most consistent with all of the disclosure of Hirai and, unlike Dr. Chase’s reading, does not ignore or discount some of the permissions. *Id.* ¶ 98 (discussing Dr. Chase’s cross-examination testimony regarding the “create” permission).

Petitioner raises two principal arguments in the Reply. Reply 18–20. First, Petitioner argues that Hirai does not teach that the access controls are at the network file system level. *Id.* at 16. Petitioner contends that the “create” and “delete” commands ignore the fact that an administrator could use the “create” and “delete” commands to control the formation and removal of partitions. *Id.* at 19 (citing Ex. 1008 ¶¶ 12–13). However, the portions of Hirai cited to support these statements merely establish that the disk is divided into partitions. Ex. 1008 ¶¶ 12–13. Petitioner cites to no evidence that would establish that the administrator in Hirai would create or delete partitions after they are established. Indeed, it is directly inconsistent with Dr. Chase’s testimony under cross-examination that “since the partition already exists, create permission can’t refer to a permission to create the partition. So it must mean something else.” Ex. 2055, 322:22–323:4. Petitioner contends that “‘execute’ would be nonsensical in a remotely located storage NFS-level solution” and that

IPR2014-01207

Patent 7,051,147 B2

“*Hirai*’s sharing device 3 would have no way of enforcing an execute permission because the remote devices would of course execute the files locally, without the intervention or cooperation of the sharing device 3.”

Reply 19. Even if it were appropriate to ignore portions of the references, there is no evidence cited to support Petitioner’s allegation that “execute” is nonsensical. See *In re Wesslau*, 353 F.2d 238, 241 (CCPA 1965) (“It is impermissible within the framework of section 103 to pick and choose from any one reference only so much of it as will support a given position to the exclusion of other parts necessary to the full appreciation of what such reference fairly suggests to one of ordinary skill in the art.”). Thus, we do not find it persuasive. Moreover, Petitioner fails to explain how this establishes that *Hirai*’s access controls must, therefore, be block level. Thus, we do not find this argument overcomes Patent Owner’s significant evidence to the contrary.

Second, Petitioner argues that Patent Owner’s argument is irrelevant because it relies on the combination of *Bergsten* and *Hirai* to teach “access controls,” and that Patent Owner’s arguments are only an attack on the references individually, which is insufficient. Reply 20 (citing *Keller*, 643 F.2d at 426; *In re Merck & Co.*, 800 F.2d 1091, 1097 (Fed. Cir. 1986)). Petitioner argues that “[t]he petition explains that, to the extent *Bergsten* fails to describe the privileges associated with write-protecting data, *Hirai*’s access controls may be incorporated into *Bergsten*’s storage controller (which operates at the block level, not the file level).” *Id.* (citing Pet. 45–46). The Petition notes that *Bergsten* allows write-protection of certain blocks, but then vaguely asserts that “[t]o the extent that Patent Owner attempts to argue that *Bergsten* may lack explicit and nuanced

IPR2014-01207

Patent 7,051,147 B2

detail regarding the implementation of access controls and the ramifications of write-protecting data upon a single storage controller of a daisy-chained storage controller network, the access control map described in Hirai is detailed with a greater degree of particularity.” Pet. 45. We are not persuaded that this presents the combination that Petitioner now argues, in which the access controls are obtained from Bergsten rather than Hirai, in sufficient detail. Indeed, that is not how we recognized the combination at institution. *See* Dec. 10–11. Even assuming that this new variation on the combination was presented, we do not find this argument persuasive because, even assuming that Petitioner is relying on Bergsten and Hirai to teach this element, the question of whether Hirai discloses high level or low level protocols is not irrelevant—it is relevant to assessing the adequacy of the rationale for combining and modifying Bergsten and Hirai in the manner Petitioner proposed.

Dr. Chase testifies in his Declaration that “[i]n the combined system [of Bergsten and Hirai], the partition control table of Hirai would be merged with the map of Bergsten to implement access controls to particular data sections. The access controls would be based upon logical addressing.” Ex. 1010 ¶ 250. Dr. Chase also testifies that “[t]he effort to merge the access rights allocations of Hirai into the mapping tree (or table) of Bergsten would be a straightforward exercise for one of skill in the art at the time.” *Id.* ¶ 251. However, on cross examination, when asked about the “create” permissions that undeniably do not apply at the block level, Dr. Chase testified that “this is immaterial to me because I understand them to be an illustration of how this table might be used to represent various access rights and certainly read and write access are applicable in

IPR2014-01207

Patent 7,051,147 B2

the scenario that we're concerned with and in the combination that we've used Hirai for." Ex. 2055, 325:23–326:13. Dr. Chase continued that "as I said, the interpretation of create permission is immaterial to me because read and write permission are clearly applicable in the combination." *Id.* at 325:6–327:13. Dr. Chase testified similarly with respect to the "execute" permission. *Id.* at 327:24–328:25.

This type of reasoning—where relevant parts of the reference are disregarded for the proposed combination without sufficient explanation of why a person of ordinary skill would do so—is precisely the type of hindsight reasoning that must be rejected. "Care must be taken to avoid hindsight reconstruction by using 'the patent in suit as a guide through the maze of prior art references, combining the right references in the right way so as to achieve the result of the claims in suit.'" *Grain Processing Corp. v. Am. Maize-Prods. Co.*, 840 F.2d 902, 907 (Fed. Cir. 1988) (quoting *Orthopedic Equip. Co. v. United States*, 702 F.2d 1005, 1012 (Fed. Cir. 1983)). We have been asked without sufficient justification to carve out and perhaps modify the access controls disclosed in Hirai and combine them with Bergsten to hold that the addition of a certain type of access controls to Bergsten would have been obvious. But "[t]his type of piecemeal analysis is precisely the kind of hindsight that the Board must not engage in." *In re NTP, Inc.*, 654 F.3d 1279, 1299 (Fed. Cir. 2011). Petitioner has not explained why a person of ordinary skill, without the claims in front of them, would have been motivated to take the access control table of Hirai and merge it with the alleged map of Bergsten in the manner that they have proposed. The only thing that Petitioner suggests is that a person of ordinary skill could have done it, but that is not the test of

IPR2014-01207

Patent 7,051,147 B2

obviousness. *See Belden, Inc. v. Berk-Tek LLC*, 805 F.3d 1064, 1073 (Fed. Cir. 2015) (“Obviousness concerns whether a skilled artisan not only *could have made but would have been motivated to make* the combinations or modifications of prior art to arrive at the claimed invention.”).

Petitioner’s analysis of all challenged claims relies on the same principles. Accordingly, we find that Petitioner has failed to show by a preponderance of the evidence that claims 14–39 are obvious over the combination of Bergsten and Hirai.

E. Objective Indicia of Non-Obviousness

Factual inquiries for an obviousness determination include secondary considerations based on evaluation and crediting of objective evidence of nonobviousness. *Graham v. John Deere Co.*, 383 U.S. 1, 17–18 (1966). Notwithstanding what the teachings of the prior art would have suggested to one of ordinary skill in the art at the time of the invention, the totality of the evidence submitted, including objective evidence of nonobviousness, may lead to a conclusion that the challenged claims would not have been obvious to one of ordinary skill in the art. *In re Piasecki*, 745 F.2d 1468, 1471–72 (Fed. Cir. 1984).

Secondary considerations may include any of the following: long-felt but unsolved needs, failure of others, unexpected results, commercial success, copying, licensing, and praise. *See Graham*, 383 U.S. at 17; *Leapfrog Enters., Inc. v. Fisher-Price, Inc.*, 485 F.3d 1157, 1162 (Fed. Cir. 2007).

To be relevant, evidence of nonobviousness must be commensurate in scope with the claimed invention. *In re Huai-Hung Kao*, 639 F.3d 1057, 1068 (Fed. Cir. 2011) (citing *In re Tiffin*, 448 F.2d 791, 792 (CCPA

IPR2014-01207

Patent 7,051,147 B2

1971)); *In re Hiniker Co.*, 150 F.3d 1362, 1369 (Fed. Cir. 1998). In that regard, in order to be accorded substantial weight, there must be a nexus between the merits of the claimed invention and the evidence of secondary considerations. *In re GPAC Inc.*, 57 F.3d 1573, 1580 (Fed. Cir. 1995). “Nexus” is a legally and factually sufficient connection between the objective evidence and the claimed invention, such that the objective evidence should be considered in determining nonobviousness. *Demaco Corp. v. F. Von Langsdorff Licensing Ltd.*, 851 F.2d 1387, 1392 (Fed. Cir. 1988). The burden of producing evidence showing that there is a nexus lies with the patent owner. *Id.*; *Prometheus Labs, Inc. v. Roxane Labs, Inc.*, 805 F.3d 1092, 1101–02 (Fed. Cir. 2015).

1. Long-Felt Need

Patent Owner presents arguments regarding long-felt need in its Response. PO Resp. 56. Patent Owner’s evidence of long-felt need includes selected quotes from an article by an expert used by Petitioner in a co-pending lawsuit and citations to testimony by the same expert to the effect that “before Crossroads’ invention, there was no such thing as a storage router and that the term ‘storage router’ did not exist.” *Id.* (citing Ex. 2038, 14; Ex. 2029, 103:18–24, 104:15–105:1, 136:6–14).

“Establishing long-felt need requires objective evidence that an art-recognized problem existed in the art for a long period of time without solution.” *Ex parte Jellá*, 90 USPQ2d 1009, 1019 (BPAI 2008) (precedential).

We have reviewed the cited testimony (Ex. 2029, 103:18–24, 104:15–105:1, 136:6–14), and we do not find it to demonstrate a long-felt need. The testimony is directed to whether the term “storage router” was

IPR2014-01207

Patent 7,051,147 B2

used in the art in the late 1990s. *See, e.g., id.* at 104:24–105:1. It does not address what the needs or problems of the art were at that time. Thus, we do not find it supports Patent Owner’s contention.

The article cited by Patent Owner (Ex. 2038), which suggests that a problem might have existed in file system performance generally, nevertheless does not establish that there was long-felt need for the claimed invention. Patent Owner has proffered no evidence as to how long this problem had been recognized, the extent of the problem, whether it remained unresolved at the time of the invention, and whether the invention resolved this need. *See Perfect Web Techs., Inc. v. InfoUSA, Inc.*, 587 F.3d 1324, 1332–33 (Fed. Cir. 2009). As such, we find that Patent Owner has not shown adequately that there was any long-felt need.

2. *Commercial Success*

Patent Owner submits evidence of the number of products it has sold, revenue from those sales, and the relative sales of its various products as demonstrating the commercial success of the claimed invention. PO Resp. 56–60 (citing Ex. 2043; Ex. 2044). Petitioner argues that Patent Owner’s attempt to establish a nexus between the alleged secondary considerations and the claimed invention falls short. Reply 22–23.

Evidence of commercial success “is only significant if there is a nexus between the claimed invention and the commercial success.” *Ormco Corp. v. Align Tech., Inc.*, 463 F.3d 1299, 1311–12 (Fed. Cir. 2006). To establish a proper nexus between a claimed invention and the commercial success of a product, a patent owner must offer “proof that the sales [of the allegedly successful product] were a direct result of the unique characteristics of the claimed invention—as opposed to other economic

IPR2014-01207

Patent 7,051,147 B2

and commercial factors unrelated to the quality of the patented subject matter.” *In re Huang*, 100 F.3d 135, 140 (Fed. Cir. 1996).

As a threshold matter, Patent Owner has not established a nexus between its commercial product and the features of its claimed invention. Patent Owner’s technology includes many features besides those identified as allegedly non-obvious in the ’147 patent. Patent Owner has not shown that the items listed in its summary sheets embody the claimed invention, or that sales of the listed products resulted from the novel, non-obvious features of the claimed invention rather than other features. *See Ormco Corp.*, 463 F.3d at 1312–13 (evidence did not show that commercial success was due to claimed and novel features).

Even if Patent Owner had established a nexus between its marketed technology and the invention claimed in the patent, its commercial success argument would not be persuasive. Patent Owner’s declarant’s statements that certain products include “mapping” or “access controls” (Ex. 2043 ¶¶ 5–6) are insufficient to show commercial success of the claimed invention. An important component of the commercial success inquiry is determining market share associated with the alleged success, relative to all competing products. *In re Applied Materials, Inc.*, 692 F.3d 1289, 1300 (Fed. Cir. 2012). Even sales volume, if provided without market share information, is only weak evidence, if any, of commercial success. *Id.* at 1299. Here, the fact that Patent Owner sold a certain number of these devices and that they made up a certain share of its sales is insufficient to establish commercial success without some context about the larger market. *See In re Baxter Travenol Labs.*, 952 F.2d 388, 391–392 (Fed. Cir. 1991).

IPR2014-01207

Patent 7,051,147 B2

3. *Licensing*

Patent Owner argues that “[a]s shown in Exhibit 2050, a large number of licensees have taken a license directed specifically to Crossroads’ ’972 patent family.” PO Resp. 59 (citing Ex. 2050). Patent Owner submits that “[t]he total license payments through FY2014 are over \$60 million” and that “[p]rominent members of the industry have paid millions of dollars to Crossroads in exchange for a license.” *Id.* Patent Owner concludes that because these companies were willing to pay millions of dollars to license the invention claimed in the ’972 patent family, the claims are not obvious. *Id.*

“While licenses can sometimes tilt in favor of validity in close cases, they cannot by themselves overcome a convincing case of invalidity without showing a clear nexus to the claimed invention.” *ABT Sys., LLC v. Emerson Elec. Co.*, 797 F.3d 1350, 1361–62 (Fed. Cir. 2015); *see also Iron Grip Barbell Co. v. USA Sports, Inc.*, 392 F.3d 1317, 1324 (Fed. Cir. 2004) (“Our cases specifically require affirmative evidence of nexus where the evidence of commercial success presented is a license, because it is often ‘cheaper to take licenses than to defend infringement suits.’”); *SIBIA Neurosciences, Inc. v. Cadus Pharm. Corp.*, 225 F.3d 1349, 1358 (Fed. Cir. 2000) (“[T]he mere existence of these licenses is insufficient to overcome the conclusion of obviousness, as based on the express teachings in the prior art that would have motivated one of ordinary skill to modify [other prior art].”).

Indeed, the mere existence of several licenses, without more specific information about the circumstances surrounding the licensing, is not a good indicator of nonobviousness. In *EWP Corp. v. Reliance Universal*

IPR2014-01207

Patent 7,051,147 B2

Inc., 755 F.2d 898, 907–08 (Fed. Cir. 1985), the Court of Appeals for the Federal Circuit stated that such licensing programs “are not infallible guides to patentability. They sometimes succeed because they are mutually beneficial to the licensed group or because of business judgments that it is cheaper to take licenses than to defend infringement suits, or for other reasons unrelated to the unobviousness of the licensed subject matter.”

Here, we lack sufficient information about the circumstances surrounding these licenses to be able to assess whether they truly weigh in favor of nonobviousness. Patent Owner directs us to no testimony from any licensee regarding why the licensee took a license from Patent Owner. It is unknown how much of the decision to take a license stems from a business cost-benefit analysis with regard to defending an infringement suit or from another business reason, rather than from acknowledged merits of the claimed invention. Patent Owner does not provide any information about how many entities refused to take a license, or why they refused.

In addition, as Patent Owner admits, these licenses are directed to an entire family of patents. Without more evidence, we are unable to determine whether the claimed subject matter of the ’147 patent was the motivator for taking the license. Given these circumstances, we determine that Patent Owner has failed to establish an adequate nexus between the claimed invention of the ’147 patent and the licenses. Thus, we do not find Patent Owner’s evidence of licensing weighs in favor of nonobviousness.

IPR2014-01207

Patent 7,051,147 B2

IV. PETITIONER'S MOTION TO EXCLUDE

We have reviewed Petitioner's Motion to Exclude (Paper 59), Patent Owner's Opposition to the Motion (Paper 64), and Petitioner's Reply in support of the Motion (Paper 70). Petitioner moves to exclude Exhibits 2300–2304, 2306–2323, 2035–36, 2043 ¶ 6, 2044, 2045, and 2050.

Exhibit 2311, which is a chronology of events leading up to the filing of the '972 patent application, is fairly termed a demonstrative. It cites to Exhibits 2300–2304, 2306–2310, and 2312–2323. Even when we consider Exhibits 2300–2304, 2306–2310, and 2312–2323, or any portions of Exhibit 2311 that reference Exhibits 2300–2304, 2306–2310, and 2312–2323, we determine that they do not provide sufficient corroboration of reduction to practice. Similarly, even when we consider Exhibits 2035–36, 2043 ¶ 6, 2044, 2045, and 2050, we determine that they do not provide sufficient support for Patent Owner's objective indicia arguments.

Accordingly, because we are in agreement with Petitioner's position on these issues for the reasons set forth above, even when considering the evidence that Petitioner seeks to exclude, Petitioner's Motion to Exclude is dismissed as moot as to these exhibits.

V. PATENT OWNER'S MOTION TO EXCLUDE

We have reviewed Patent Owner's Motion to Exclude (Paper 61, "PO Mot. to Exclude"), Petitioner's Opposition to the Motion (Paper 66, "Pet. Opp. Mot. To Exclude"), and Patent Owner's Reply in Support of the Motion (Paper 70). Patent Owner moves to exclude certain cross examination testimony of Dr. Levy, Mr. Middleton, and Exhibits 1008, 1009, 1224, 1225, and 1226. PO Mot. to Exclude. We consider each in turn.

IPR2014-01207

Patent 7,051,147 B2

Patent Owner seeks to exclude certain cross examination testimony of Dr. Levy because “it was obtained pursuant to objectionable questioning and/or mischaracterizes his testimony.” PO Mot. to Exclude 1. Patent Owner seeks to exclude testimony of Mr. Middleton because Petitioner mischaracterizes his testimony “via selective citation.” PO Mot. to Exclude 11. Petitioner responds that these objections go to the weight that should be given the evidence, not its admissibility. Pet. Opp. Mot. to Exclude 6, 9. We agree with Petitioner. Regarding exhibits 1009, 1224, 1225, and 1226, we did not rely on either the testimony to which Patent Owner objects or any of the exhibits identified in Patent Owner’s motion. Patent Owner also seeks to exclude Exhibit 1008 as having an improper certificate of translation. However, even considering Exhibit 1008, we find for Patent Owner on the asserted ground of unpatentability based on Hirai. Accordingly, for these reasons, we deny-in-part and dismiss-in-part as moot Patent Owner’s Motion to Exclude.

VI. PATENT OWNER’S MOTION TO SEAL

Patent Owner filed several exhibits (Exhibits 2044, 2045, 2050, and 2052) under seal, along with a motion to seal (Paper 27) and a protective order (Paper 28). We previously granted Patent Owner’s motion for entry of the default protective order. Paper 53. Patent Owner’s motion to seal is unopposed. Patent Owner’s motion to seal is *granted*.

There is an expectation that information will be made public where the information is identified in a final written decision, and that confidential information that is subject to a protective order ordinarily would become public 45 days after final judgment in a trial, unless a motion to expunge is granted. 37 C.F.R. § 42.56; Office Patent Trial

IPR2014-01207

Patent 7,051,147 B2

Practice Guide, 77 Fed. Reg. 48,756, 48,761 (Aug. 14, 2012). In rendering this Final Written Decision, it was not necessary to identify, nor discuss in detail, any confidential information. However, a party who is dissatisfied with this Final Written Decision may appeal the Decision pursuant to 35 U.S.C. § 141(c), and has 63 days after the date of this Decision to file a notice of appeal. 37 C.F.R. § 90.3(a). Thus, it remains necessary to maintain the record, as is, until resolution of an appeal, if any.

In view of the foregoing, the confidential documents filed in the instant proceeding will remain under seal, at least until the time period for filing a notice of appeal has expired or, if an appeal is taken, the appeal process has concluded. The record for the instant proceeding will be preserved in its entirety, and the confidential documents will not be expunged or made public, pending appeal. Notwithstanding 37 C.F.R. § 42.56 and the Office Patent Trial Practice Guide, neither a motion to expunge confidential documents nor a motion to maintain these documents under seal is necessary or authorized at this time. *See* 37 C.F.R. § 42.5(b).

Petitioner filed a number of documents (Exhibits 1217–1223) under seal without filing a corresponding motion to seal those documents. *See* 37 C.F.R. § 42.14. If a motion to seal is not filed within 20 days of this decision, those documents will be made public.

VII. CONCLUSION

For the reasons expressed above, we determine that Petitioner has shown by a preponderance of the evidence that claims 14–39 are unpatentable as obvious over the CRD Manual, CRD-5500 Data Sheet, and Smith, as well as Kikuchi and Bergsten. The relatively weak secondary evidence of non-obviousness, diminished further by Patent Owner's failure

IPR2014-01207

Patent 7,051,147 B2

to show nexus to the claimed invention, is not sufficient to overcome the relatively strong evidence of obviousness presented by Petitioner. *See Ohio Willow Wood Co. v. Alps South, LLC*, 735 F.3d 1333, 1344 (Fed. Cir. 2013) (requisite nexus between secondary indicia and invention must be shown for evidence to be accorded substantial weight, and where a claimed invention represents no more than the predictable use of prior art elements according to established functions, evidence of secondary indicia is often inadequate to establish non-obviousness). Petitioner has *not* shown by a preponderance of the evidence that claims 14–39 are unpatentable as obvious over Bergsten and Hirai.

VIII. ORDER

For the reasons given, it is:

ORDERED that claims 14–39 of the '147 patent have been shown to be unpatentable;

FURTHER ORDERED that Petitioner's Motion to Exclude is *dismissed as moot*;

FURTHER ORDERED that Patent Owner's Motion to Exclude is *denied-in-part and dismissed-in-part as moot*;

FURTHER ORDERED that Patent Owner's Motion to Seal Exhibits 2044, 2045, 2050, and 2052 is *granted*;

FURTHER ORDERED that Exhibits 1217–1223 are to be unsealed within 20 days of this Final Written Decision, unless a motion to seal those exhibits is filed; and

FURTHER ORDERED that because this is a Final Written Decision, parties to the proceeding seeking judicial review of the Decision must comply with the notice and service requirements of 37 C.F.R. § 90.2.

IPR2014-01207
Patent 7,051,147 B2

FOR PETITIONER:

Greg H. Gardella
Oblon, McClelland, Maier & Neustadt, L.L.P
CPDocketGardella@oblon.com

Scott McKeown
Oblon, McClelland, Maier & Neustadt, L.L.P
cpdocketmckeown@oblon.com

FOR PATENT OWNER:

Steven Sprinkle
Sprinkle IP Law Group
ssprinkle@sprinklelaw.com

John Adair
Sprinkle IP Law Group
crossroadsipr@sprinklelaw.com

Russell Wong
Wong, Cabello, Lutsch, Rutherford & Brucculeri, LLP
CrossroadsIPR@counselip.com

James Hall
Wong, Cabello, Lutsch, Rutherford & Brucculeri, LLP
CrossroadsIPR@counselip.com

Keith Rutherford
Wong, Cabello, Lutsch, Rutherford & Brucculeri, LLP
CrossroadsIPR@blankrome.com